

Planetary Pan Mixer

“P” Series

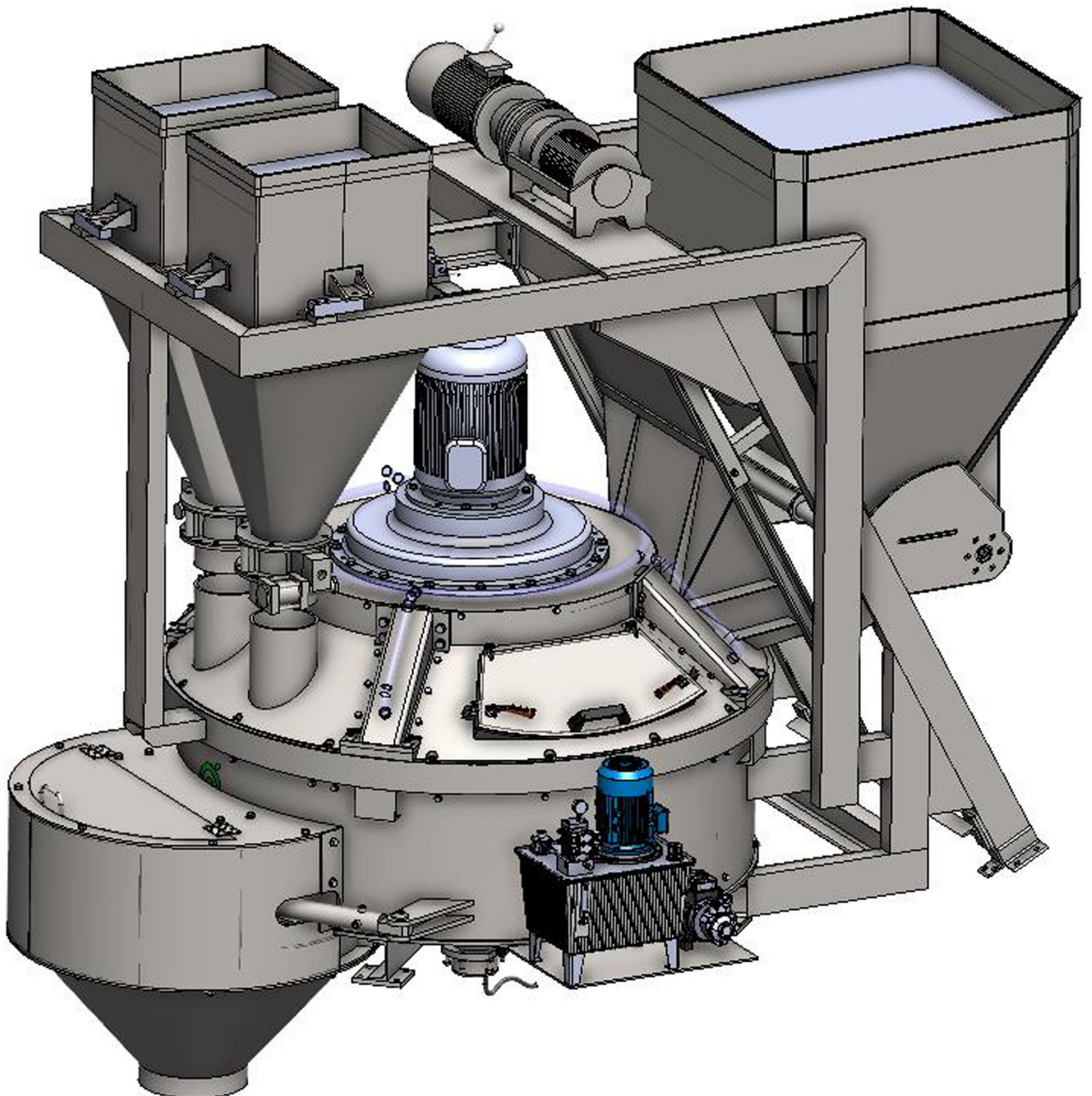

About Pan Mixer

“P” series have high quality pan mixer models Having Heavy Duty Planetary Motion Stirrer from Top Drive for Quick and Homogenous Mixing for Heavy Duty Material Mixing Application

Standard Feature :-

- Having Planetary Motion Stirrer for Quick and Homogenous Mixing
- Direct Drive
- Top Safety Cover
- Swiveling Type Discharge with Chute By Hydraulic
- Bolted Liners provided
- Water spray bar
- Limit Switch for Top Safety Cover
- All parts interchangeable
- No Foundation Required
- Plug & Start
- Lifting Hook

Optional Feature:-

- Digital water meter
- Material Loading System
- VFD Provided
- Material Hopper with Load Cell

Technical Specification :-

Particular	Model								
	PM 10 P	PM 15 P	PM 20 P	PM 33 P	PM 50 P	PM 87 P	PM 100 P	PM 120 P	PM 150 P
Maximum Input (lit.)	150	200	300	500	750	1125	1500	1875	2250
Output Capacity (lit.)	100	150	200	330	500	875	1000	1500	1750
Maximum Load Capacity (kg.)	240	300	480	750	1200	1800	2400	3000	3600
Motor Power Input (kW/HP)	3	5	7.5/10	10/15	18.5/25	30/40	45/60	55/75	60/80
RPM of Slewing Body	17	17	13	13	12	12	10	10	10
RPM of Star Rotors	51	51	39	39	36	36	36	36	36
Number of Mixing Arm	3	3	3	3	3	3	3	6	6
Number of Scrapers	1	1	1	1	1	1	1	2	2
Hydraulic Power Pack Motor (HP)	0.5	1	1	2	2	3	5	5	5

Note:-

- Capacity and Motor Power consider as per general material , Can be very as per application
- Can be customized mixer as per specific client needs
- Due to continuous development in the design, specification & dimensions are subject to change without prior notice
- Ele. Power 50Hz, 3Phase